

4B+ Security Upgrade Kit – 3696

Installation Instructions

For 3600 Series Front Loading Horizontal Mailboxes

U.S.P.S. Approved

Kit Contents

Front Security Plate
Security Government Door
Rear Security Plate
Arrow Lock Double Bolt Catch
Arrow Lock Security Catch
Bag of Hardware
 (4) 3/16"x7/32" blind rivets
 (4) 1/4"-20x3/4" carriage bolts, lock washers and hex nuts
 (4) #10 flat washers and #10-32 locknuts
 (4) #6x3/8" flat head self-tapping screws
Installation Instructions

Tools Required

Stubby #2 Phillips Screwdriver
#2 Phillips Screwdriver
Slotted Screwdriver
Hammer
File
Blind Rivet Gun
Center Punch
7/16" Socket Wrench
3/8" Socket Wrench
Drill motor
Right Angle Drill Head Adapter
7/32" diameter Drill Bit, (Stub or Screw-Machine Length)
1/8" diameter Drill Bit

Disassembly

The postal delivery person must open the government door compartment to provide access to install a new Arrow Lock catch and an assembly replacing the old government door.

Remove the existing government door with a small slotted screwdriver or center punch. Open the government door and look at the hinge pins at the edge of the inside of the door. There is a top pin, a bottom pin and a spring in between the two pins. Insert the screwdriver into the groove in the lower of the two hinge pins, pull the hinge pin up and carefully tilt the bottom of the government door out until the pin is free of the doorframe. Be careful when removing the door as there is a spring between the upper and lower hinge pins. Trap the pins and spring with your hand so they do not become airborne. Discard the hinge pins and spring as they are no longer needed.

Remove the USPS Arrow lock from the old door by removing the four nuts attaching the lock to the studs in the door. The lock will be reinstalled on the new security cover assembly.

Remove and discard the old service door handle attached to the rear of the doorframe by removing two screws with the stubby #2 Phillips screwdriver. See Illustration 1 on the next page.

Installation of New Front and Rear Security Plates

Place the new rear security plate in the opening in the rear of the doorframe. See Illustration 1. Center the plate and mark the centers of the four holes. Drill the four holes 1/2" deep in the two horizontal doorframe members using the 1/8" diameter drill bit. Fasten the rear security plate to the doorframe with the four #6x3/8" flat head self-tapping screws. Do not over-tighten the four screws.

Place the new government door and front security plate over the rear security plate from the front of the doorframe. Fasten the assembly with the four 1/4"-20x1" carriage bolts, lock washers and hex nuts.

Install the Arrow Lock double bolt catch and Arrow Lock over the studs protruding from the rear of the new government door. Fasten with four #10 flat washers and #10-32 locknuts. Align the Arrow Lock bolt with the bolt catch before tightening the locknuts. You may need the assistance of the postal delivery person to do this alignment.

Replacement of Arrow Lock Security Catch

Remove the old catch by drilling out the two rivet heads with a 7/32" diameter drill bit in a right angle drill head adapter. Dress the rough edges of the holes with a file.

Enlarge the A holes with 7/32" diameter drill bit in the right angle drill head. See Illustration 2. Insert two blind rivets from the inside through the forward holes in the catch bracket and the A holes in the wall of the mailbox compartment. With the catch bracket thus located, drill two more holes with the 7/32" diameter drill bit in the right angle drill head. Permanently install the four blind rivets.

Close the doorframe and confirm the proper alignment of the Arrow Lock in the government door and catch in the mailbox compartment. Adjust the position of the Arrow Lock until the lock bolt properly engages the Arrow Lock security catch.

SALSBURY INDUSTRIES

18300 Central Avenue, Carson, CA 90746-4008

Phone: 1-800-624-5269

Int'l Phone: 323-846-6700

Fax: 1-800-624-5299

Int'l Fax: 323-846-6800

www.mailboxes.com

engineering@mailboxes.com

Copyright © 2020 Salisbury Industries. All rights reserved.

Illustration 1

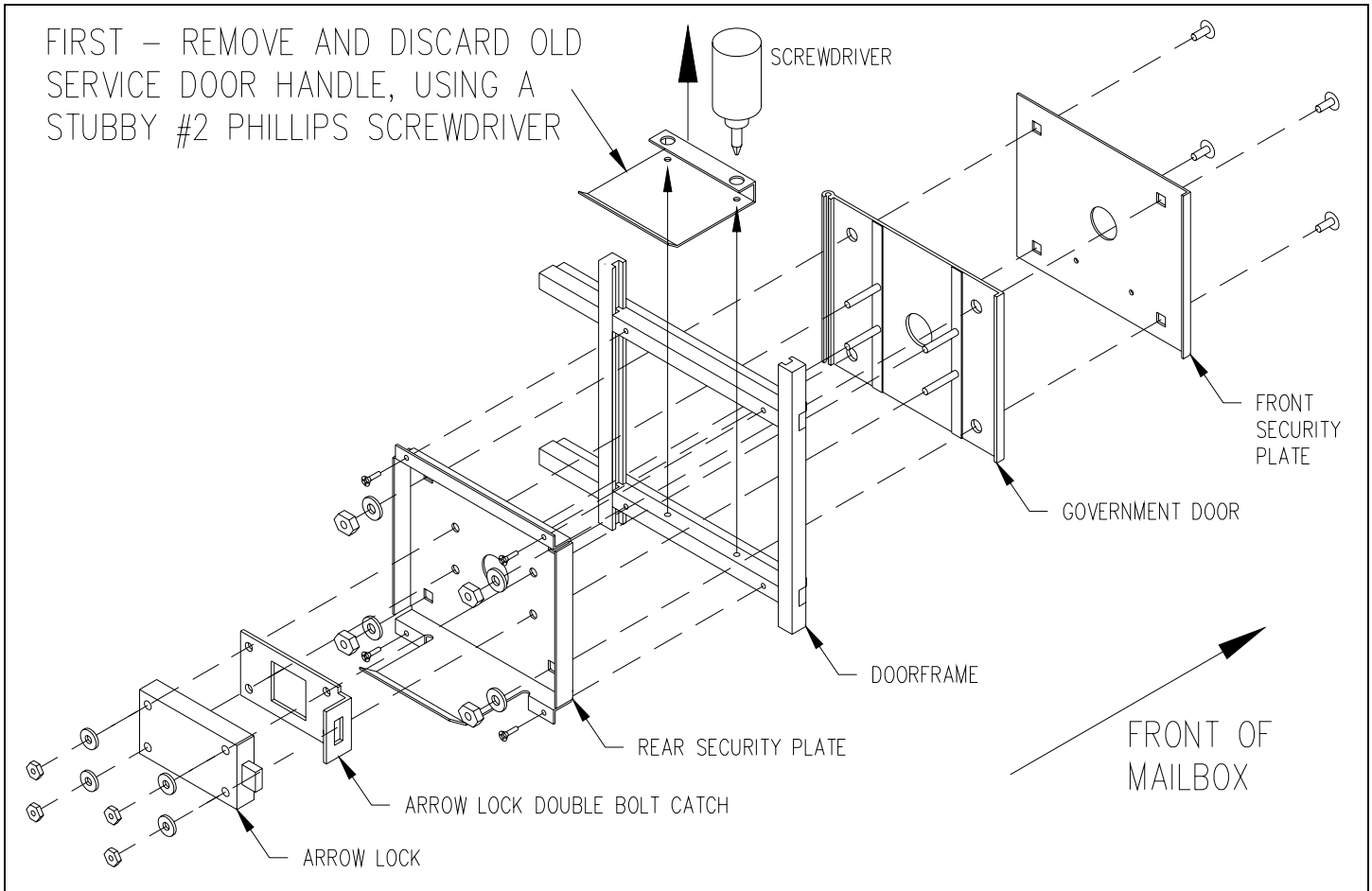
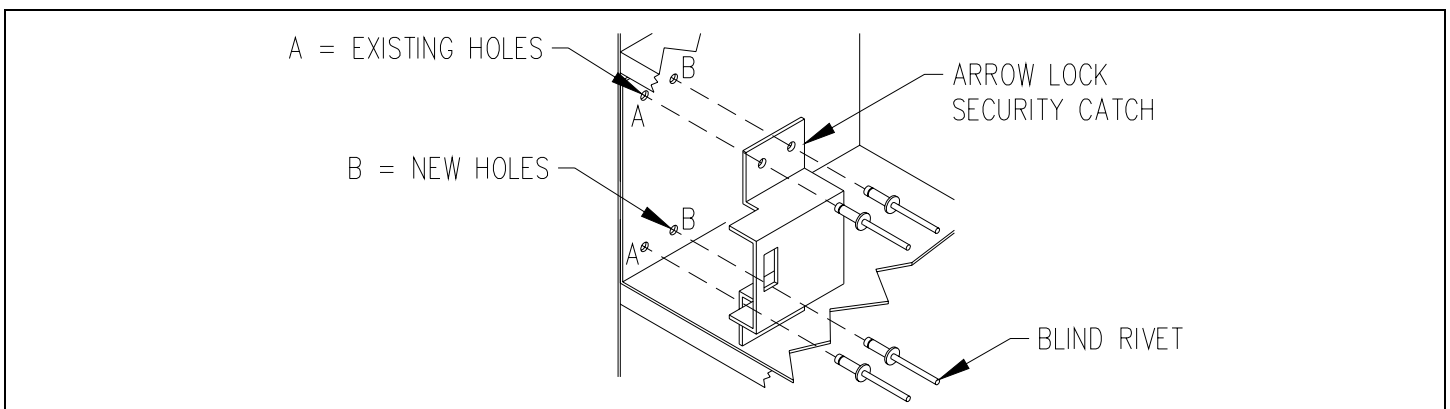

Illustration 2



SALSBURY INDUSTRIES

18300 Central Avenue, Carson, CA 90746-4008

Phone: 1-800-624-5269

Int'l Phone: 323-846-6700

Fax: 1-800-624-5299

Int'l Fax: 323-846-6800

www.mailboxes.com

engineering@mailboxes.com

Copyright © 2020 Salsbury Industries. All rights reserved.